

LIFTING CLAMP for Laying concrete material

(Adjustable clamping range type)

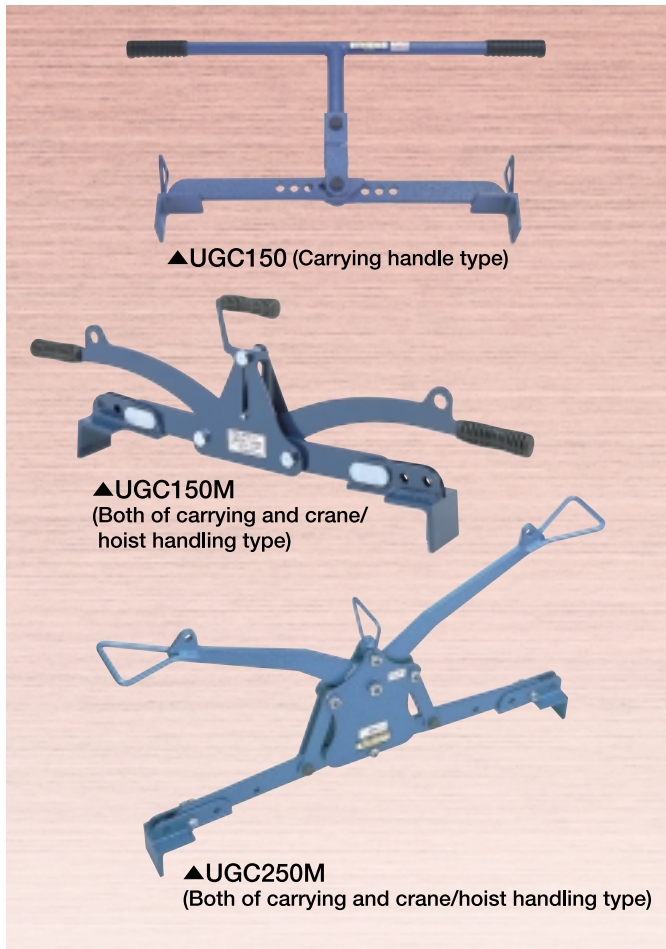

UGC 150~250M

Ideal clamps for laying and handling of reinforced concrete U-shaped gutters, lids for U-shaped gutters, curbs and concrete blocks

FEATURES

- The clearances between the reinforced concrete structures can be easily aligned with the 9 mm thick claws of these clamps.
- These clamps will suspend a work piece from both ends and not interfere with a leveling string.
- By changing the location of the toggle pins, the clamping range can be easily adjusted to the length of the work piece.
- The direction of the handle of UGC150 can be changed 90° .
- The teeth on the claws of these clamps will provide a positive grip on the work piece.
- UGC150M and UGC250M can be used with cranes and hoists or as hand held clamps.
- The clamping force increases in proportion to the weight of the load.

SPECIFICATIONS

Item No.	Rated capacity (kg)	Jaw opening (mm)	Weight (kg)	Remarks
UGC 150	150	400~ 600	5	
UGCS150M	150	400~ 600	8	
UGC 250M	250	580~1050	16	

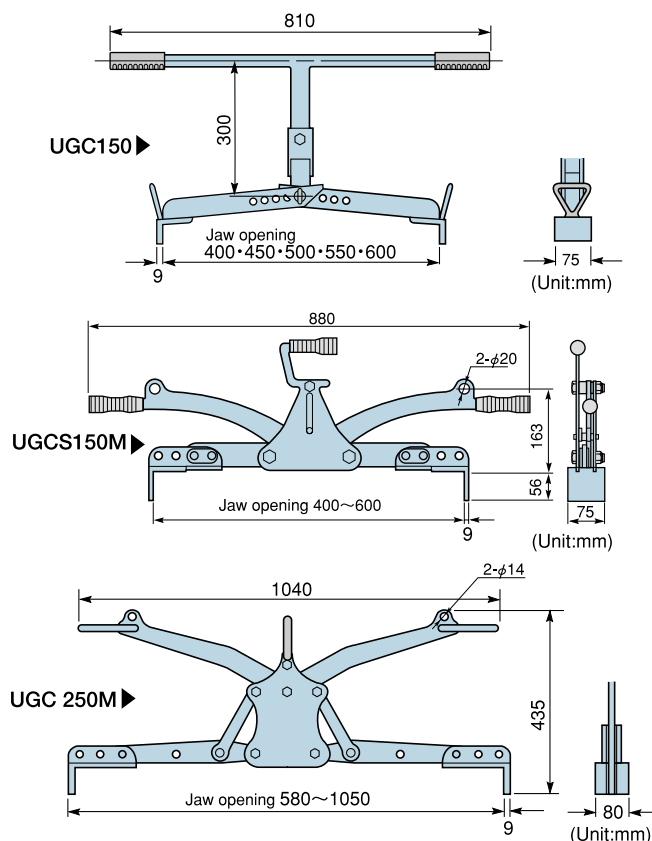

EXAMPLES OF USE

